



HOUSINGS UNCONDITIONALLY GUARANTEED

Diaphragm seals, also referred to as gauge guards, employ a chemically resistant diaphragm to protect and isolate process fluids from gauges and other process instrumentation. Diaphragm seals can be used in both pressure and vacuum conditions, and are available with and without a factory installed gauge.

Safety Symbols

Observe all safety symbols in installation and operation instructions. The following symbols indicate cautions, warnings and notes that must be observed for safe and satisfactory installation, operation and maintenance.

-  **WARNINGS** Danger of serious injury or death could occur if these warnings are ignored.
-  **CAUTIONS** Equipment damage, injury or death could occur if these cautions are not observed.
-  **NOTES** Special instructions for safe and satisfactory installation, operation and maintenance.

General Safety







-  Remove all pressure from pumping system before disassembly, removal or maintenance.
-  Always wear safety glasses and other appropriate safety equipment when installing, operating or repairing.
-  **WARNING!** GLYCERINE OR SILICONE COULD RESULT IN A SPONTANEOUS CHEMICAL REACTION OR EXPLOSION WHEN COMBINED WITH STRONG OXIDIZING AGENTS INCLUDING (BUT NOT LIMITED TO) CHLORINE, OXYGEN, HYDROCHLORIC OR NITRIC ACID AND HYDROGEN PEROXIDE. **DO NOT** USE GLYCERINE OR SILICONE FILLED GAUGES OR ACCESSORIES IN THESE TYPES OF APPLICATIONS. CONSULT FACTORY FOR ASSISTANCE.
-  **CAUTION!** GAUGE CASE (FIGURE 1) MAY BE FILLED WITH GLYCERINE OR SILICONE.

Figure 1

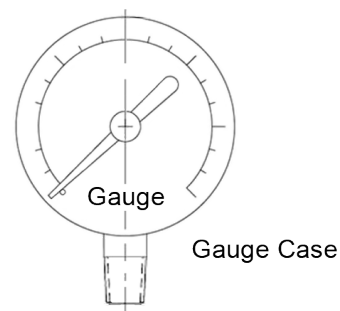

Diaphragm Seal with Factory Installed Gauge

-  The diaphragm seal housing and the gauge Bourdon tube are filled at the factory when a diaphragm seal is purchased complete with installed gauge. These preassembled diaphragm seals (FIGURE 2) are filled with glycerine, silicone or mineral oil. Consult warning tag on diaphragm seal for type of body fill.

Preassembled diaphragm seals (filled with gauge attached) are easily installed into a piping system using a close nipple and tee. PTFE tape should be used as the pipe sealant on all threads. Plastic models should be installed no more than hand tight. Plastic threads will expand as more pressure is applied. The use of tools may result in a cracked housing and possible leakage. Metal models should be tightened securely. A strap wrench can be used on metal models but do not over tighten. The sharp edge of a close nipple can rupture the diaphragm.

Use care to avoid cross-threading.

-  **DO NOT DISASSEMBLE A PREASSEMBLED** diaphragm seal except for diaphragm replacement.

Gauges on diaphragm seals are filled using a vacuum evacuation method. Disassembly will lead to loss of fill and possible air entrapment. Air or any other gas allowed to enter the filled chamber will result in inaccurate gauge or switch readings.

Figure 2

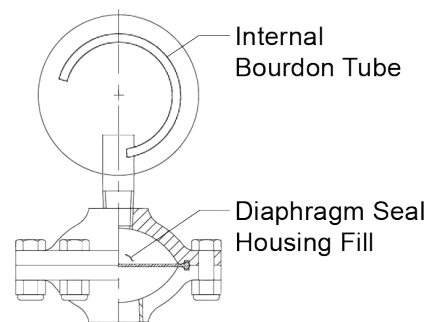

Diaphragm Seal without Factory Installed Gauge

Unassembled diaphragm seals (no fill and without gauge) must be completely filled with a temperature stable liquid fill fluid. Glycerine, silicone or mineral oil are commonly used fill fluids. Additionally, the gauge or other pressure instrument must also be filled with the fill fluid. All air must be removed from the chamber and the instrument to ensure accurate pressure/vacuum readings.

Diaphragm Seals on Pressure Gauges:

1. Pour liquid fill fluid into the diaphragm seal (gauge side) until it reaches the middle of the threads. Heating the fill fluid to the temperature of hot tap water will thin it and ease the filling process. Tap the diaphragm seal on a table or other solid surface to release any air bubbles. It is very important that no air remains in the fill side (gauge side) of the diaphragm seal.
2. The air in the Bourdon tube inside the gauge must be replaced with liquid fill fluid. Remove the snubber of the new gauge if possible. The snubber is the plug in the inlet of the gauge. It contains a very small hole which will cause difficulty in filling the gauge tube. Removal will not affect gauge performance because the diaphragm seal produces the same needle dampening effect as a snubber.
3. The Bourdon tube in the gauge can now be filled. Slowly pour or inject the liquid fill fluid into the gauge's inlet port. Heating the fill fluid to the temperature of hot tap water will thin it and ease the filling process. The best gauge fill method is the use of a 15" Hg vacuum (-0.51 bar).
4. A thin wire should be inserted into the inlet to aid in releasing the trapped air in the tube.
5. When reinstalling the gauge on the diaphragm seal, gently and lightly press up on the diaphragm with a blunt object (such as the eraser end of a pencil) as the gauge is threaded on. Failure to do so may pressurize the diaphragm seal, leading to an inaccurate gauge pressure reading. While pressing up on the diaphragm from the system side, turn the gauge over and thread it into the diaphragm seal. It is normal that some fill fluid will be lost during installation.

Diaphragm Seals on Pressure Instruments:

1. Pour liquid fill fluid into the diaphragm seal (gauge side) until it reaches the middle of the threads. Heating the fill fluid to the temperature of hot tap water will thin it and ease the filling process. Tap the unit on a table or other solid surface to release any air bubbles. It is very important that no air remains in the fill side (gauge side) of the diaphragm seal.
2. The pressure-sensing chamber of the pressure instrument must be filled completely with fill liquid allowing no air bubbles to remain. The instrument can then be installed on the diaphragm seal.
3. When reinstalling the pressure instrument on the diaphragm seal, gently and lightly press up on the diaphragm from the system side with a blunt object (such as the eraser end of a pencil) as the instrument is threaded on. Failure to do so may pressurize the diaphragm seal, leading to an inaccurate gauge pressure reading. While pressing up on the diaphragm, turn the instrument over and thread it into the diaphragm seal. It is normal that some fill fluid will be lost during gauge installation.

M27E11_024

